

# Booster Pump

## Compressore

- **Adattabile:** raccordi di collegamento forniti in dotazione
- **Facilità d'installazione**
- **Silenzioso**
- **Adatto a tutti i tipi di robot a pressione**

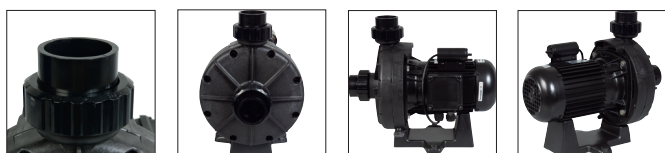

Raccordi

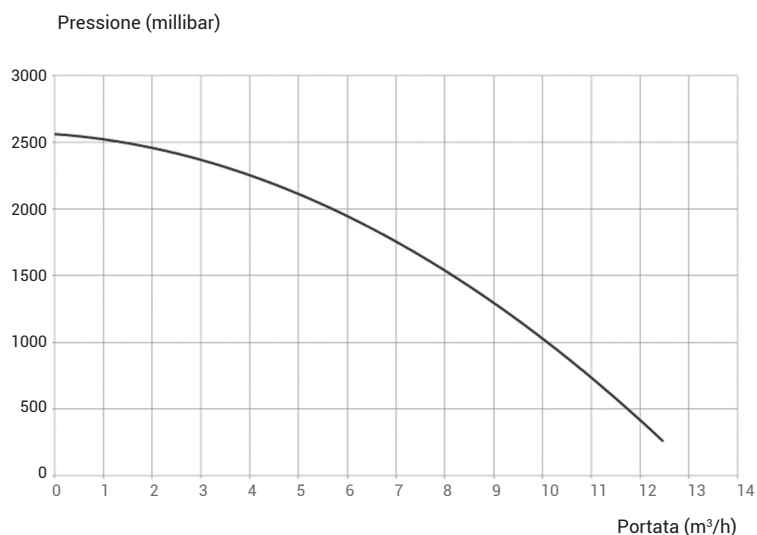
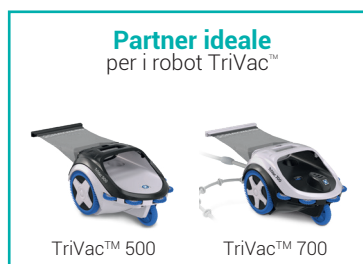
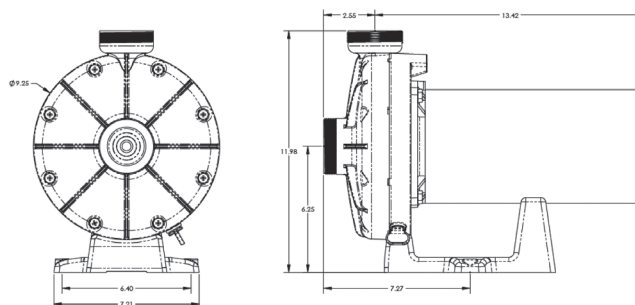

BOOSTER PUMP®

Tipo	I/O	Peso	Potenza elettrica assorbita P1	Potenza elettrica di uscita P2	Amperaggio	Rif.
1 CV	50 mm	11 kg	1100 W	830 W	4,8 A	SP6050E